

How To Install Bodies and Fenders

Part 1: Overview

The Wescott Guide

This guide is intended to be used to assemble a car using a Wescott body and an original or reproduction chassis. The guide may be of use as a reference for assembling cars with an original body and mounting original or reproduction fenders.

Check Your Chassis

The first VERY IMPORTANT step, and one often neglected, is to start with a chassis that is square, not twisted, and is accurate in critical dimensions. (See Part 1, frame inspection, below.)

Model T's and Model A's basically had simple flat top frame rail, the Model A with curved front frame horns. In 1932, Ford started kicking up the frame over the axles to lower the body. It is very important that the kickup on 1932-40 frames be correct, or many grille, hood, and body fitting problems will result. For accurate frame drawings, see the back pages of this catalog.

Assembly Overview

We recommend first checking the chassis and make sure it is correct. Then to assemble the body and interrelated parts such as fenders, grille, hood, running boards etc., and align them as a unit. This approach not only works well for Fords but most other makes as well.

Part 2: Frame Inspection

The frame must be square, with no twist, and accurate to the original Ford shape, for proper fit of all the parts. Check any and every frame before assembly, even if it has come with assurances that it is "cherry" original or from "The World's Greatest Frame Builder." A careful check takes just a few minutes, and may save you hours of frustration later. The frame should be checked before and after repairs are made, structural modifications are made, and all brackets have been welded on. Check frame before bolt on suspension and drive train items are installed.

Procedure

Step 1. "Float" the frame

Place the frame on 3 stands, one at each rear corner and one at the center of the front crossmember. This allows the frame to "float" and show any latent twist.

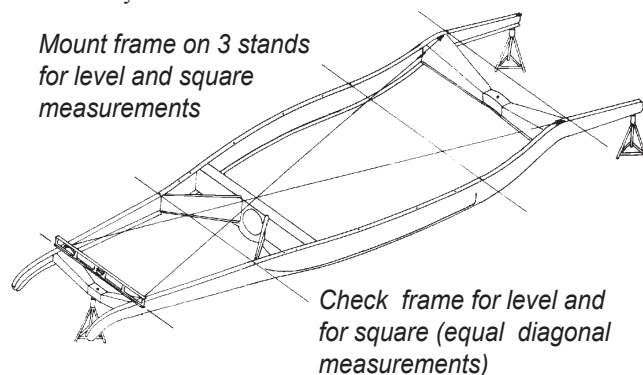

Mount frame on 3 stands for level and square measurements

Check frame for level and for square (equal diagonal measurements)

Step 2. Level Check

Shim the stands at the rear until the frame is level across the rear stands. Using a carpenter's level, check the frame for level across the front and rear crossmembers and several places between.

Keep the level facing the same direction to maintain accuracy of readings. Out of level readings will indicate humps, sags, or twist (readings that are progressively out of level on one side moving away from the rear indicate a twisted frame.)

Step 3. Cross Measure for Square

Cross measure the frame (in a "X" pattern) between various pairs of points across from each other on the frame rails. Measure from a point on one frame rail to a point on the other rail, then measure between points opposite the first set of points. Pairs of points that should be measured include from the middle to the front, from the middle to the rear, overall from front to rear, and between cross members. On a "square" frame each leg of a pair of measurements will be equal to the other leg. Pairs of measurement that are not equal show "diamond". A frame can show "diamond" overall, or in local areas if it has been pushed in from the side.

Step 4. Vertical Check

Check the sides of the frame rails to see that they are vertical.

This is critical for proper fitting in areas where fenders or running boards mount directly to the frame (including most 1932-40 Fords).

Step 5. Check Measurements

Check the frame for proper measurements across the frame rails at various points. Our frame diagrams (at the back of the catalog) can be used as a reference. It is especially important on 1932-40 Fords that the frame have the proper width and the front and rear kickups be correct as it affects the relationship and fit of the radiator, grille, hood, and front fenders to the body and running boards.

Making Corrections

If any corrective action is necessary it may be best to have the work done at a professional frame alignment shop, as adequate pushing and pulling tools and anchor points are seldom available at a casual shop. If corrective work is done, go through the complete check again. The work may not have been done properly or may have created other problems.

Part 3: Chassis Assembly

Step 1. Assemble to complete rolling stage

The chassis should be finished to "complete rolling" stage, but before final paint. The motor, transmission, rear end, driveline, front and rear suspension, steering gear, brakes, wheels and tires, etc. should be installed. Other parts such as the master cylinder, pedal assemblies, brake lines, fuel tank, etc. should be installed if mounted directly to the chassis.

Step 2. Locate mounting holes or drill for body, radiator

Check locations on the frame of mounting holes for the body and radiator. Our frame diagrams (at the back of the catalog) are available as a guide. If these mounting holes are not drilled, do so at this time. Access should be available inside the frame for nuts, lockwashers, and wrenches. If frame boxing plates or chassis parts interfere with bolt locations, nuts or cage nuts should be installed.

Body to frame bolts should be at least 3/8" diameter, grade 5. Lockwashers or locknuts should be used.

Step 3. Locate bolting points for doors

The minimum number of body to frame bolting points to maintain door alignment are at each side of the front of the cowl, at the front of each door opening, at the rear of each door opening, and as close to the rear of the body as practical.

Step 4. Install welt and pads

Install chassis anti-squeak welt as needed. On 1926-32 Full fendered cars (and 1933-34 Pickups) install welting on the top of the frame from the front of the frame to the last body mount. Welt pads also should go on top of the splash apron at each body mount. 1926-32 Fenderless cars should have welt from the cowl to the rear body mount. 1933-34 Passenger cars should have welt installed from the firewall to the rear body mount and on top of the center X rails. 1935-36 Passenger cars use rubberized cork pads, 1937-48 Passenger cars use molded rubber pads, and 1932-41 Pickups use rubber pads between the wood blocks and the frame.

Part 4. Fender and Running Board Installation

1926-34: Mount running board brackets to frame. Check location to frame diagrams. Tweak as necessary so brackets are at right angle to chassis center line and parallel to each other. Clamp (do not bolt at this time) 1926-31 splash aprons in approximate location.

1926-40: Loosely bolt or clamp (do not tighten at this time) running boards to frame or brackets.

1928-32: Mount front splash apron to frame. Note that 1930-32 uses special studs which also mount the front bumper brackets. 1930-31 front fenders and front apron extend forward of the frame.

1926-36 (and 1937-39 Pickup): Drill front fenders for headlight bar or headlight stand mounting holes as necessary.

1926-40: Bolt front fender support braces to frame. All 1926-32 and 1933-34 Pickups use a single heavy support brace on each fender. 1933-36 Passenger cars and 1935-39 Pickups use a heavy headlight support brace with a reinforcing strut to the front cross member and a brace at the rear of the wheel opening. 1937-39 Passenger cars use a strut from the inner fender to the front cross member and a brace at the rear of the wheel opening. 1940-48 cars use a support yoke from the front cross member to the inner fenders and baffle braces at the rear of the wheel opening.

1933-40: Clamp or drill and loosely bolt inner front fenders to frame. Install fender brace or inner fender support struts.

1926-40: Clamp front fenders to frame, running boards, inner fenders and fender brackets. Clamp or loosely bolt fender brace behind wheel on 1933-48 models. Most reproduction fender braces require some reworking for proper fit. The fender should not have to be forced over or pulled down to the bracket. The bracket should touch the fender only at bolt locations and the headlight bar or stand mounts. The front fender bracket should be adjusted to support fiberglass fenders without tension to help prevent cracking problems. The bracket should have a slight

forward pull at the outside edge of steel fenders to help pull the bead edge straight.

1926-31: Adjust running board aprons to proper fit with front fenders and running boards. Clamp aprons to front fenders.

1926-36 Loosely bolt headlight bar or stands to fenders. Install shims between fenders and fender brackets if necessary to prevent distorting fenders.

1926-29: Install hood shelves and wood blocks.

1926-32: Carefully tighten headlight bar or stand to fender bracket bolts. Use a carpenter's level to check level across headlight mounts. Use a plumb bob or carefully cross measure to check that headlight bar is centered in relation to frame. Adjust fender brackets as necessary to set headlight bar position.

1926-48: Double check fit of front fenders, aprons, running boards, etc. When satisfied with fit and alignment drill remaining holes and securely bolt. If any body mount holes are covered by splash aprons or front fenders, drill fender or aprons for bolt clearance.

Part 5: Radiator and Grille Installation

Step 1. Install hood lacing on radiator shell or grille. Mount any emblems, trim or ornaments to the grille or grille shell if mounting bolts will be inaccessible when grille is installed on radiator.

Step 2. Mount the radiator to the frame. Use the special radiator mounting kit with springs, as these help avoid radiator damage due to frame flex or road vibration. Install the radiator shell or grille to the radiator (1933-34 uses special spacers).

Step 3. Install inner splash baffles on 1933-40. These baffles help direct proper airflow through radiator. Install hood hinge brackets (if used) on radiator shell or grille.

Part 6: Install Body To Frame Mounting Pads & Blocks

Install wood body to frame spacer blocks to body if used. Most 1926-31 steel sub framed cars and 1932-40 Pickups use hardwood spacer blocks. Most Wescott 1928-31 bodies are designed to use modified original style wood blocks. The Wescott 1926-27 Roadster, 29 Hiboy, and 1931 coup floorpans do not use wood blocks.

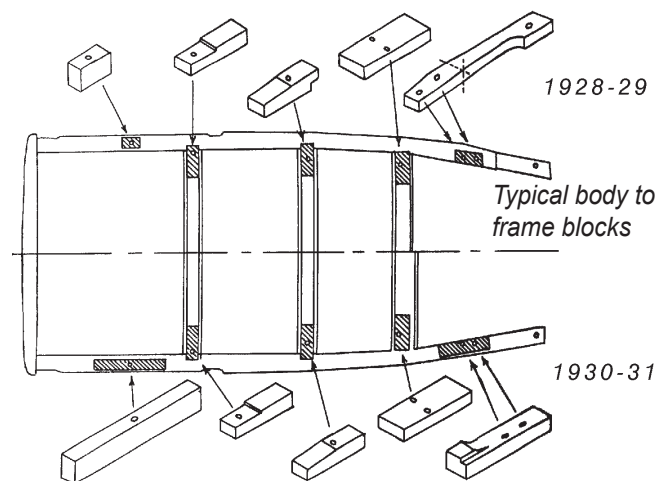

Reproduction blocks can be easily modified to fit Wescott bodies or blocks can be made up from "scratch". Place the body upside down and sand the top of the block for rough fit with the bottom of the floorpan. We use a 36 grit disc on a 5" rotary sander. Scuff sand the block mount area on the floorpan and glue using an epoxy or other suitable adhesive. When the glue has hardened, sand the block until flush with the lower edge of the body. Glue or staple 3" strips of chassis welt to the block at body mount location.

1932-1934 Passenger cars used a rubberized fabric pad between the body and frame. We recommend using a continuous strip of "chassis welt".

1935-36 Passenger cars used rubberized cork and rubber body to frame pads. 1937-48 Passenger cars used rubber body to frame pads. 1940 Convertibles used a thick (appx. 1/4") steel pad with a thin rubber pad. This type of rigid mount at the cowl and door post is necessary for good door alignment on Convertibles. Rubber pads at these mount points simply allow too much flex.

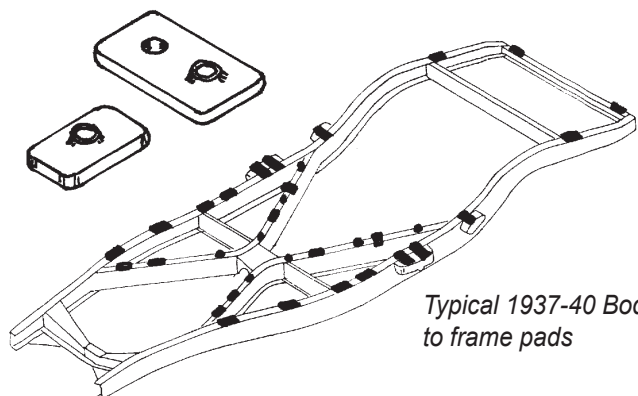

Typical 1937-40 Body to frame pads

1932-47 Pickups used a heavy wood body to frame spacer block. The proper shape and spacing are important for proper body to fender and hood alignment.

Part 7: Body Installation & Alignment

Step 1. Set the body on the frame.

Position chassis so frame is level across cross members and body mounts. Set the body on the frame. Position body using the hood top length for reference to the distance between cowl and grille or radiator shell. Check to be sure that the body is centered on the frame at the cowl, door posts, and rear wheelwells.

Step 2. Install hardware.

Install radiator support rods, rear hood hinge brackets (if used), and hood lacing to the cowl. Install the hood and hood latches. On 1926-32 cars (and 1933-34 Pickups) if stock latches are not used, bolt fender to frame at latch mount locations.

Step 3. Shim to level.

Shut and latch doors on body. Shim the body so it is level across the cowl at the windshield posts or post mounts, at the back of the front doors, and at the back of the deck lid opening or rear quarter panels.



Use a U shaped shim for fitting. Attach a wire "tail" for easy removal. Replace with washers when done

Common Alignment Situations

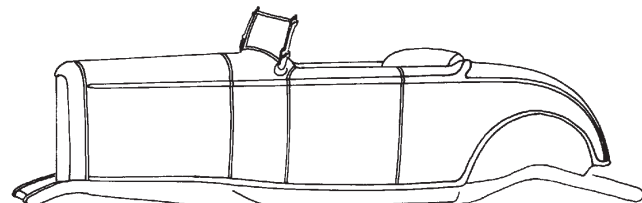

A. Body is aligned properly. Reveals line up. Door and Hood gaps are even.

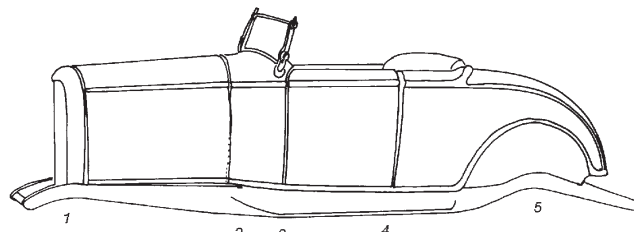

B. Body is too high at middle (reference points 2,3, and 4). Wide gap at top of door tapering to normal at bottom. Normal gap at hood top front tapering to wide at bottom. Rear bottom of hood overlaps cowl, normal gap at top.

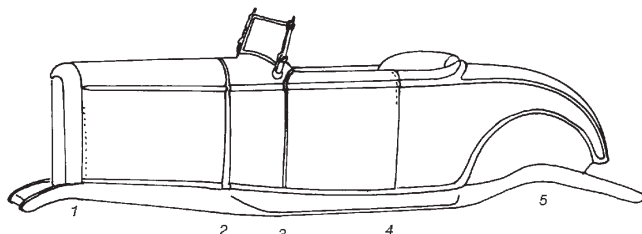

C. Grille and rear of body are high (reference points 1 & 5). Doors overlap quarter at top. Wide gap at lower rear of hood tapering to normal at top. Lower front hood overlaps grille, normal gap at top.

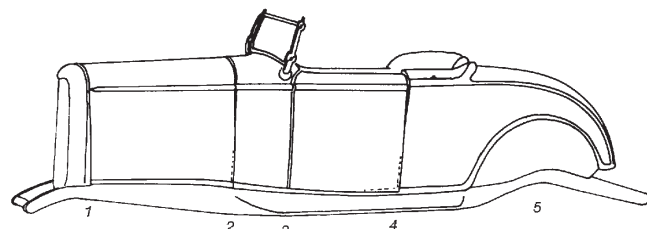

D. Body is too high at front of cowl (reference 2) Doors overlaps and drops at quarter, Grille is pulled back. Back lower corner of hood overlaps cowl. Normal gap top front of hood tapering to wide at bottom.

Step 4. Rear fenders.

Clamp rear fenders to running boards and body. Shim and adjust the body from side to side as necessary for proper fender fit. Keep the body level by adding the same height shims from side to side. It may be necessary to loosen and adjust running boards and splash aprons. Check and shim as necessary for fuel tank clearance on 1932-40 models.

Common Alignment Situations

Doors are aligned properly with slightly out at the top on each side. Especially on roadsters this helps the doors latch properly and not rattle

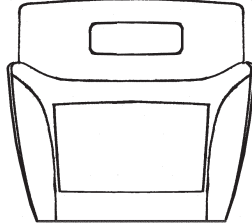

One door hangs out at the bottom, and the opposite is in at the bottom. Note this should be checked with the doors unlatched. Correct by shimming the body counterclockwise, or the cowl clockwise. Opposite on suicide door cars.

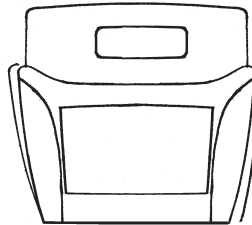

Both doors hang out at the bottom

This cannot be corrected by shimming. This is a failure of the body cross structure. The door posts will need to be spread and body cross structure repaired.

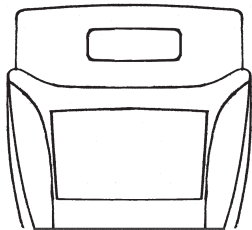

Step 5. Level and shim again.

Shim the body and or the radiator so the reveal line of the hood, cowl, doors, fenders, inner fenders, and body is visually correct. It may also be necessary to shim the hood lacing so the hood sits at the proper height. The clearances between the hood and cowl or grille, and doors to door post should be even from top to bottom. Check the body for levelness again and shim as necessary. The body should now be located properly on the chassis. All Wescott bodies are aligned for proper door fit at the factory. The above methods may not be adequate for a body which is out of square across the cowl or quarter panels, a more extensive body adjustment may be indicated.

Step 6. Body mount locations.

Scribe body mounting hole locations on the body using body mount holes in the frame as a guide. Drill any remaining mounting holes for front or rear fenders, inner front fenders, grille, etc. Remove body from frame and drill body mount holes. Mark all shim heights and locations to help when re-shimming. Reinstall body on frame. Install body to frame bolts (do not tighten yet). The body will need to be checked for levelness again and shims added or removed as necessary.

Step 7. Door & hood clearance.

Check the door clearance between inner panel and door jambs; this should be even top to bottom. Open and close doors; each door latch should engage the striker without the door having to be forced up, down, forward, or back. The doors on all Wescott bodies are built with a slight preload so the bottoms of the doors close tighter than the tops. This gives a firm latching action and helps prevent rattles. The preload should be equal from side to side. Check for proper hood to fender or inner fender clearance.

Step 8. Tighten bolts.

When shims are inserted, tighten all body mount bolts. Use lockwashers or lock nuts. Check body alignment again, and re-shim if necessary.

Step 9. Finish bolting.

Bolt rear fenders to running boards and body. Install fender welt if desired. Clamp in place any back panels, rear rolled pans, or rear frame horn covers. When satisfied with alignment and fit, drill all remaining mounting holes and bolt securely.

About shims

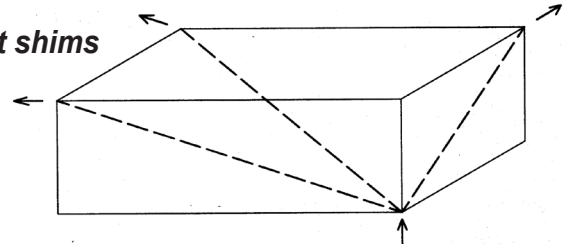

It is important to note that a shim at any one bolt mount will affect the alignment of both sides of the car. For example, adding a shim at the right front cowl mount will move the top of the right door in and slightly down, move the top of the left door out and down, move the right upper corner of the cowl away from the hood, and may affect level measurement across the cowl. A shim in a different area may compensate for some movement. After adding the shim in the example above, if another shim is inserted at the left front door post, it will move the top of the left door up, move the front of the left cowl closer to the hood and affect the level measurement across the cowl in the opposite way the first shim did.

Part 8: Accessory Installation

We recommend that all other parts be fitted and installed, such as the windshield assembly, headlights, taillights, cowl lights, bumpers, door and deck handles, etc. The car should be brought to as near a fully assembled condition as possible. All parts should fit and any modifications should be made before painting or plating any parts.



How to Prepare Fiberglass for Paint

Step 1. Test Fit

First, and always TEST FIT ALL PARTS BEFORE PAINTING! It will only cost you time and frustration if you have to do a minor modification to a part that is already painted. In addition most parts suppliers are reluctant to accept a return if you find the part is not to spec and you have painted it.

Step 2. Preparation: Sand and Fill

Preparation Overview

The difference between a poor paint job and a terrific paint job often has little to do with spraying the paint. It has to do with preparation. This is not a difficult job, but it requires patience and an eye for perfection. And whether you are an amateur or professional, the techniques are the same. Basically, preparation is a three-step process which you repeat until the car is as smooth as you want it. First, you block sand to contour. Second, you fill low spots. Third, you primer. Each time you do this, you should be filling and block sanding smaller areas. If you goof and miss a high area or go too far on a low one, just fix it the next time around.

Door & Deck Lid Clearance

The first place you will need to begin looking for high and low spots is in the clearances around the doors and decklid. Your body and related parts should be aligned and shimmed in place before starting. Generally, you will want to make the gaps match width along the entire length of the opening, although ours are pretty good to begin with. (If the gaps seem way off, go back and re-check your alignment.)

Gap Width

Deciding on a correct width for the gaps is a compromise. Show cars, which are not driven on real roads, generally have narrower gaps than "drivers" because the motion of any car, metal or fiberglass, can cause narrower gaps to vibrate together and paint to chip. Keep in mind that the addition of primers and paints will reduce clearances. The gaps on our bodies are normally adequate, but still need to be checked to make sure there will be enough clearance with the addition of paint. You need to allow at least 1/16" clearance (before paint) in all body configurations, so check your clearance with the doors open and decklid open as well as closed. Also check the clearance along the entire arc as you open and close them. You should make sure that there is at least 1/16" clearance at all times.

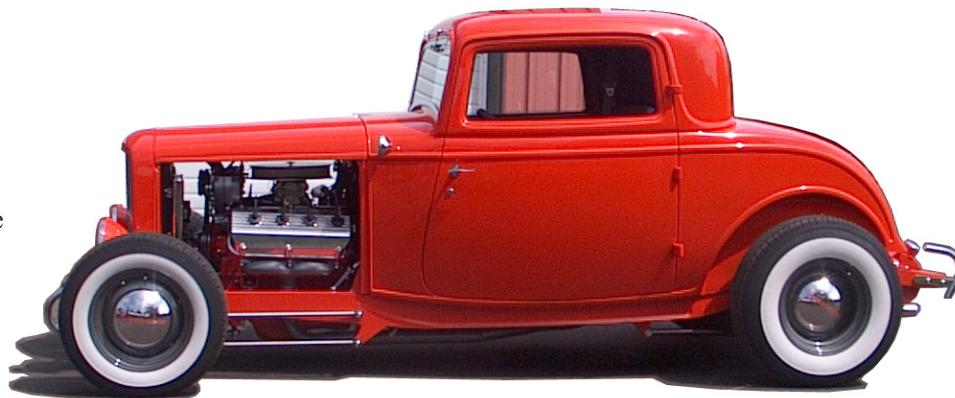

Adjusting the Gap

If you want to grind the gaps to make them wider or fill them in to make them narrower this is your next step. Always SAND or GRIND THOROUGHLY any area to be filled to assure adhesion of the filler. In areas that need more clearance, grind off high spots carefully. Don't go through the fiberglass layup!!! It is not a problem to grind through the gelcoat, as you can later cover the area with primer or filler. Remember to keep checking the contour of your gaps as you sand and fill.

Choose Your Putty

Use a good grade of catalyzed polyester body filler. (Be sure to use the catalyst recommended by the manufacturer -- they are not all the same). Polyester fillers and primers have basically the same chemical composition as fiberglass resin so they should be totally compatible. In addition, catalyzed fillers and primers do not shrink like air-dry materials. Also, always use fillers that can be water-sanded. (Check the manufacturer's recommendation). These are easier to work with and do not absorb moisture, which can be a problem. Follow the manufacturer's directions for your particular putty, and fill the areas you have prepared.

Disassemble the Car

Now disassemble the car as much as is necessary for paint. If you are removing the body from the chassis, be careful to mark all shims, heights, and locations. You may want to do this in several steps: Remove the body while the doors and decklid are still on it. Next paint the chassis, body floor, and firewall. Now reassemble and re-shim the body before you remove the doors and decklid to paint them and the body.

Sand & Fill Seams

Before moving on to priming, you will want to do a little more sanding and filling. Sand all mold seams and other rough areas (including any filler you have used on the gaps) with a hand held block. This can be done with 80 to 220 grit paper; sand carefully to avoid doing any damage to areas surrounding mold seams. It is easy to over-sand and end up with a flat spot.

Sand & Fill Low/High Areas

Most professionals and other picky people would sand the entire body and related parts at this time, carefully watching for low and high spots. Low spots are easy to see because as you sand through the black gelcoat finish, it appears gray. The finish on low spots does not abrade if you are using a fairly stiff block, so these spots will remain black. (If you are sanding on other gelcoats that do not appear different colors, and also in subsequent steps on our parts, you will have to apply a guide coat to get this same effect. More about that later).

How to Prepare Fiberglass for Paint, cont.

High Spots

High spots will, of course, be the first areas to sand down. You may end up sanding all the way through the gelcoat and into the fiberglass layup. This is perfectly O.K. as long as you don't sand through the layup, because the area will be painted with primer. However, since our parts are very straight to begin with, this should be rare, so double-check! (This is a little different than the process you would use on metal. When you are block sanding metal and a high spot shows it cannot be sanded down, but must be worked down carefully with a hammer and dolly).

Sanding Blocks

Sanding blocks can be of any shape, size, or material to do the job you intend to do, but the more rigid the block, the better it will cut high spots and leave low spots. The more flexible it is (such as a rubber block) the easier it will follow contours (including ripples). Basically, you will want to start out with a harder block for your first sanding steps, and move to a softer block for your final sanding(s) with the finer grit paper.

Sanding Tips

When block sanding with any block, you must take care to use a diagonal or somewhat sideways operating pattern with the block to avoid cutting grooves with the sides of the sandpaper. Hold the block at an angle to the direction that you are sanding. When sanding into corners, where you are forced to hold the block head-on, care must be taken not to gouge material around the area to be sanded. It sometimes helps to make your own miniature sanding block by wrapping sand paper around paint stir-sticks or other handy objects--but you still have to be careful.

Final Sanding & Filling

After this initial sanding, any areas that still appear black are low and should be filled. But before you fill, be sure to SAND or GRIND these areas to assure good bonding. Since you will be sanding off the black finish, you may want to mark the areas first. Once again, use a good grade of catalyzed polyester filler.

Step 3. Primer

After all high areas and filled areas have been water-sanded to proper contour with 220 grit paper, all sanded areas should be primed. This is best done by an experienced painter.

Choose Your Primer

Primer selection requires careful planning. Each material used must be able to adhere to the base material under it. We recommend that you use a two-part sanding primer that does not require air drying and does not shrink after curing. Most catalyzed polyester primers will adhere well to a fiberglass or polyester filler base. (As with filler, be sure to use the recommended catalyst for your primer). Polyester primers and fillers are incompatible with self-etching primers. Never use a self-etching primer over a polyester primer, polyester body filler, or fiberglass! Also, never use a polyester primer or body filler over self-etching primer. Check the primer manufacturer's recommendations for use and incompatibilities for any other type of two-part catalyzed primer.

High Areas

Be careful when you primer over an area that was high, particularly if you are not priming the surrounding area. The primer adds thickness, and you may just end up sanding it all off again unless you are careful to feather in the edges of the primed area.

Pinholes

Sometimes small air bubbles will come through the primer and burst, causing pinholes. This often occurs when you primer over filler or over areas where you have sanded through the gelcoat. If pin holing occurs, primer can be brushed, squeegeed, or "gun puttied" to fill the holes. (To "gun putty" set your paint gun on narrow fan, and blow primer into the holes). Once again we want to caution you against using an air-dry material for this operation because of secondary shrinkage.

Sand it All Again

Now you start the whole process over again, to catch any high or low spots that you missed the first time, or that you created while fixing another problem. You can again choose to do the whole car, or just select areas. This time, use 220 grit wet paper on your hand held sanding block.

Guide Coat

To be able to block sand effectively you should use a guide coat, since you have already removed all or part of the original black finish. A guide coat consists of a very light application of a contrasting color sprayed over the area to be sanded. As you sand, the guide coat is removed, letting you know that you have sanded thoroughly. Areas where the guide coat doesn't sand off are low, and should be filled. Even "rattle can" paint can be used for the guide coat, because you will be sanding off the entire coat each time.

Fill Low Spots

After block sanding with 220 grit wet paper over the guide coat, fill any low spots with your catalyzed polyester filler or primer. Make sure areas to be filled have been thoroughly sanded before putting filler in. (Sand off the guide coat).

Primer Again

If filler has been used or if the gelcoat has been sanded through, these areas should then be primed. (Be sure to sand the filled areas first). Fill any pin-holes with primer.

Repeat

These steps can be repeated as many times as is necessary to get your body to its desired smoothness. Professionals and other perfectionists may sand and fill an entire car five or six times. Not just on our bodies--ours are actually straighter to begin with than most original and reproduction Fords.

Final Sand

When you are satisfied that the car is as smooth as you want it and after all areas sanded with 220 grit wet paper have been primed, guide coat the entire area to be painted. For the final block sanding, use a more flexible block with 320 grit wet paper for solid color paint jobs or 360 grit wet paper for metallic colors, unless your paint manufacturer has different recommendations.

How to Prepare Fiberglass for Paint, cont.

Always be sure to check your paint manufacturer's directions before taking anyone else's advice. Even ours!!!!

Another Tip

Sand each primer coat in only one direction; don't criss-cross or circle. Good professional painters primer and sand the entire car several times, sanding each primer coat in a different direction--up, down, and both diagonals. The final sanding should follow the line of the car from front to back.

Step 4. Sealer Selection

Choose Your Sealer & Paint

The project is now ready for sealer and paint. The sealer should be a good grade compatible with the top coats. It is O.K. to use air dry materials at this point, but we prefer a catalyzed sealer, since it will be used with catalyzed polyester primer and gelcoat. However, it is more important that the sealer is compatible with top coats, and not all paints come with catalyzed sealers, so follow the manufacturer's recommendation for your paint. It is usually best to buy an entire paint system (sealer and top coats--not primer) from one manufacturer, to be sure that they are compatible.

Paint Tip

Always apply your paint according to the manufacturer's recommendations. Be sure to follow the manufacturer's recommendations for personal safety equipment, ventilation, and any other requirements.

While all of these steps may seem confusing at first, remember that they are all just variations on the basic pattern of block sand, fill, primer. The block sanding step consists of spraying a guide coat, then sanding to contour. The filling step consists of sanding or grinding low spots, filling, and sanding again. Finally, the priming step consists of priming, filling pinholes, and sanding. When this is done, your car is ready for a beautiful paint job.

CAUTION: If it becomes necessary to strip paint off of fiberglass parts, you should take care not to allow removers to penetrate into the fiberglass layup. Special removers that don't attack polyesters can be used--but carefully.

How to Reduce Dust While Painting

Important Note:

The fact that we are including this article in our catalog should not be construed to mean that we recommend that amateurs attempt to paint their own cars. We don't. Painting is a difficult skill that takes years to perfect. However, even very experienced painters can be stymied when it comes to painting fiberglass. So, if you are an experienced painter, you may benefit by the following advice. If you are not, you may want to pass this article along to your painter.

We Mean It

If any of the advice we give in this article is contrary to the paint manufacturer's recommendations, FOLLOW THE PAINT MANUFACTURER'S RECOMMENDATIONS.

Static Electricity and Dust

Fiberglass is more difficult to keep dust free than metal when you are painting, because it has a tendency to build up static electricity, which attracts dust. Rubbing the surface with a tack cloth to remove this dust only generates more static electricity. It's just like rubbing a balloon on your hair. The extra static electricity attracts even more dust. So what can you do? Ideally, you would either eliminate the dust in the environment or you would eliminate the static electricity. Neither of these is 100% effective, however, so you have to do a combination of the two.

Eliminate Dust

Eliminating as much dust as possible is the first step. Scrub down your room. Make sure that it is isolated from dusty areas. You may even want to filter incoming air. It sounds easy, right?

Reduce Static Charge

Since no matter how hard you try, you are never going to achieve a totally dust-free environment, you need to take the next step, which is reducing the amount of static charge generated. Wash the area to be painted with a WET rag, as this doesn't generate a charge. Use the dry tack rag as little as possible. If more dust settles than you just wiped off, STOP!

Even Out Charge

Generating less static electricity helps, but doesn't solve the problem because much of the static charge generated in painting is unavoidable. Spraying paint out of a gun generates static

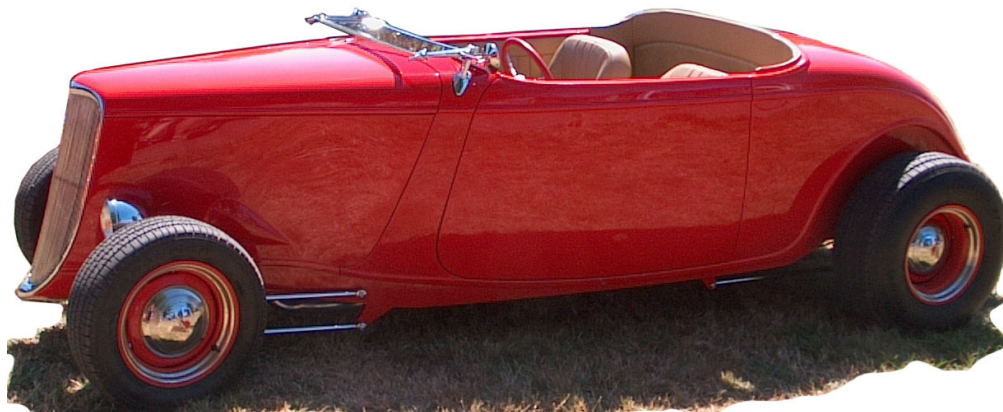

How to Reduce Dust While Painting, cont

electricity because of the friction against the gun and against the air. So you have to even out the static charges in the room.

Ground to Compressor

The only way to even out the static charges is by grounding all possible sources of static electricity-- in this case, the gun, the painter, and the item being painted. To do this, you first have to locate an adequate grounding location. The easiest is probably your compressor, since it is grounded through your electrical system. (If your compressor has plastic pipes, this won't work unless you run your ground back to where it's metal).

Ground the Gun

To ground the gun, run a stainless steel wire from the gun itself all along the length of the hose, and attach it the compressor, making sure that it is contacting metal at both ends. You can run the wire along the outside of the hose, or for a more difficult but more permanent installation, run the wire inside the hose. If you use a light-gauge wire, it won't interrupt the air flow, and running it inside the hose will protect it from wear and tear. The difficulty is getting the wire in there, because it just bends when you push it. So you have to pull it. The best way we've found to do this is to get a piece of cloth small enough to fit in the end of your hose and attach it to a long string. Blow the cloth through the hose, and pull it out the end. Attach the wire to the string and pull it on through. Make sure that the ends of the wire contact the metal connectors at the ends of the hose. If your compressor has plastic pipes, you need to continue the ground wire to the metal body of the compressor.

Ground Yourself

Now ground yourself--the painter. If you didn't have to wear rubber gloves to protect yourself from hazardous solvents in the paint, you would automatically be grounded by holding onto the grounded gun. But since you should ALWAYS wear rubber gloves while painting, you need to run a grounding wire from your bare wrists to the grounded gun. (Electronics stores sell a bracelet that works well for this. It's designed to ground computer operators to their computers.)

Ground The Item

Now all that's left is grounding the fiberglass item to be painted. Jumper cables are handy for this, but a stainless steel wire will work, too. Just attach one end of the cable or wire to your grounding location and the other end to the back or underside of the item to be painted. Be sure to attach it directly to the fiberglass or to metal that is touching the fiberglass at some point. Since fiberglass is a poor conductor, grounding one point does not necessarily ground the whole item. If it is a large item, such as a body, you want to be sure it is grounded at several points. This is no problem with our bodies, because the steel reinforcement contacts the fiberglass in numerous locations. Just attach your ground anywhere on the reinforcement. If a body is bolted to a frame it has the same effect-- the metal bolts contact the body at several points, so all you have to do is ground the frame.

Wire Management

Once you ground everything possible, you will greatly reduce the amount of dust attracted to the fiberglass. However, you may find that you are tripping over wires right and left. There are a couple of things you can do to avoid this. Instead of running the ground wire from the fiberglass directly to the ground location, it helps to put a large, flat metal plate of some sort on the floor. You can then run a ground wire from the metal plate to the ground location, and from the fiberglass to the metal plate. This will ground the item just as well, and you can walk on the plate instead of tripping over the wire. Also, if you haven't installed the grounding wire inside your hose, make sure it is firmly taped or otherwise attached along the whole length of the hose. (Or you can just attach this wire to the grounded plate, if your hose is long.)

While nothing we know of will completely solve the dust problem, these steps will certainly help. Be sure to start by eliminating as much dust as possible in your paint room, and by generating as little static electricity as possible. Then even out the static charges by grounding yourself, your gun, and the item to be painted.

