

1939 & 1940 Convertible Bodies, Cont.

Dash

3 Dash Panel Options

A fiberglass dash panel with opening glove box lid is installed in the body. 1939 and 1940 filled styles are available.

1939
Filled
Style



1939
Stock
Style



1940
Filled
Style



39 Convertible, Wescott Body, Fenders, & Hood, built by Jim Larson

Firewall

Stock or Recessed Firewall, 4 variations

Wescott firewalls are molded using a fire retardant resin. Available firewalls include:

Stock Style

Fits original Flathead V8's and some V6's

Chevy V8 Style

1" extra clearance for right valve cover and distributor
3" extra clearance for distributor

Ford V8 Style

2" recess across for small block Ford V8

Big Block Style

3 1/2" extra clearance for left valve cover
4 1/2" extra clearance for right valve cover
5 1/2" extra clearance for distributor

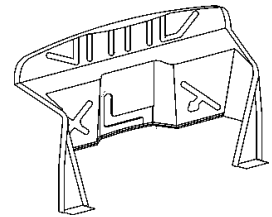
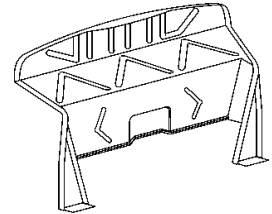
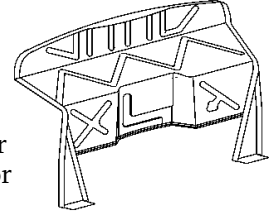
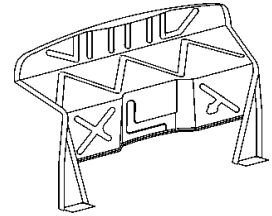

Built-in internal steel for safety & strength

Hardware mount tabs provided on steel framework to protect stress areas:

- Door hinge mounts
- Door latch mounts
- Door handle mount tabs
- Trunk or Rumble hinge mounts
- Seat belt mounts
- Top mount locations on steel frame

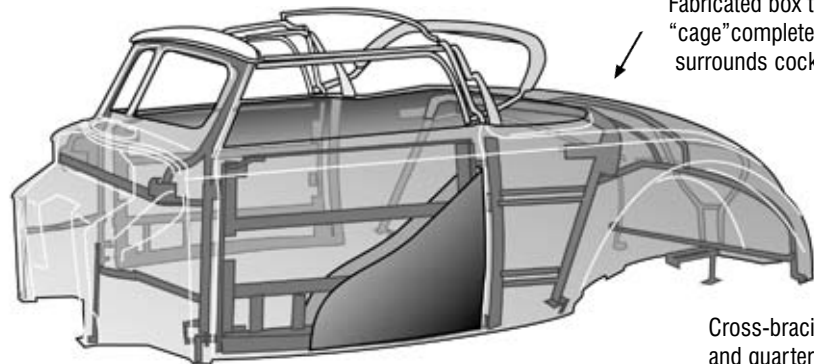

Fabricated box tubing "cage" completely surrounds cockpit

Cross-bracing of cowl and quarter panels creates exceptional rigidity and door alignment

Doors are constructed with two fiberglass panels encasing an inner steel framework

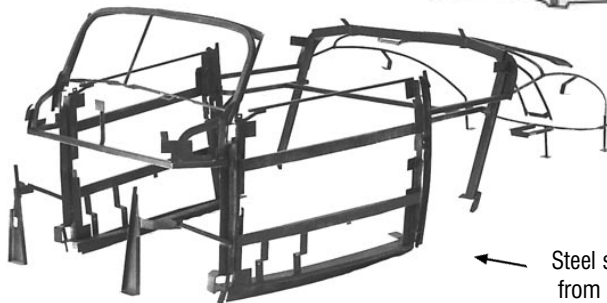

Steel side rail reinforcement from cowl to rear of cockpit

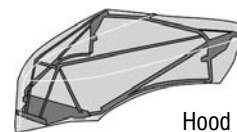

Hood and deck lid are steel reinforced